

# Combined Synthesis of Sodium and Potassium Alkoxides Using Electrochemical Methods

Kudryavtsev Pavel<sup>1</sup>, Kudryavtsev Nikolay<sup>2</sup>

1. Professor, HIT Holon Institute of Technology, 52 Golomb Street, POB 305 Holon 5810201, Israel, e-mail:pgkudr89@gmail.com.

2. Polymate Ltd - Israel Research Center, POBox 73, Migdal HaEmek 10550, Israel.

Received: April 19, 2015 / Accepted: May 18, 2015 / Published: September 25, 2016

**Abstract:** The alkoxides of chemical elements form a class of compounds, the practical value of which are large and are growing. In the present work generalizes the experience of creation of small-tonnage chemical production of alkoxides of different chemical elements and their use in technological processes of production of various chemicals and composites. In this paper the authors presented an overview of the main synthetic methods, obtaining alkoxides of chemical elements and, in particular, alkali metal alkoxides. Describe their basic physical and chemical properties. Have been analyzed the main methods of production of alkali metal alkoxides. Four basic methods of synthesis of chemical elements alkoxides have been allocated. Consider the direct methods for the synthesis of metal alkoxides by reaction with alcohols. Also have been considered, options for obtaining chemical elements alkoxides by reacting their oxides and hydroxides, with the corresponding alcohols. To implement this method has been described the functioning, the process plant scheme for obtaining potassium i-butoxide, by azeotropic distillation of water. For alkoxides of chemical elements, has been considered a variant of their synthesis method using exchange reactions with alcohols, and processes such as transesterification. The combined process of electrochemical synthesis, of sodium and potassium alkoxides has been proposed. To slow down the rate of interaction of sodium and potassium with alcohols, their amalgam has been used. The amalgam was prepared by electrolysis of sodium hydroxide. The interaction process alkali metal amalgam flows quietly enough, even in the case of methyl alcohol and potassium amalgam. Technological scheme includes three stages: electrolysis of NaOH solution at ordinary electrolyze with flow mercury cathode; dissolving amalgam on the anode in an alcohol solution and recovering sodium or potassium, in the form of alkoxides.

**Keywords:** electrochemical synthesis, sodium alkoxide, potassium alkoxide

## 1. Introduction

The alkoxides of chemical elements form a class of compounds, the practical value of which are large and are growing. In the present work generalizes the experience of creation of small-tonnage chemical

---

**Corresponding author:** Kudryavtsev Pavel, Professor, HIT Holon Institute of Technology, 52 Golomb Street, POB 305 Holon 5810201, Israel, e-mail:pavelku@hit.ac.il.

production of alkoxides of different chemical elements and their use in technological processes of production of various chemicals and composites, implemented under the supervision and with the participation Kudryavtsev P.G.

After the publication of the first review on metal alkoxides [1] in 1960 this chemistry field started to develop intensively; the review [2] (1967) already contains more than 300 links and the review [3] 1978 contains 320 links. Industrial value of alkoxides associated with their use as components soluble catalysts Ziegler-Natta in the process of olefins polymerization, as well as other chemical catalytic processes. Alkali metal alkoxides are frequently used in the synthesis of transition metal alkoxides, using exchange reactions [4]. In the journal of the Russian Academy of Sciences Russian Chemical Reviews in the period after 2003 was published on 13 reviews on the synthesis and application of the various metals alkoxides. In recent years, the number of publications devoted to alkoxides chemical elements has already reached a certain level stable and varies in the range of  $50 \pm 13$  publications per year (Figure 1).

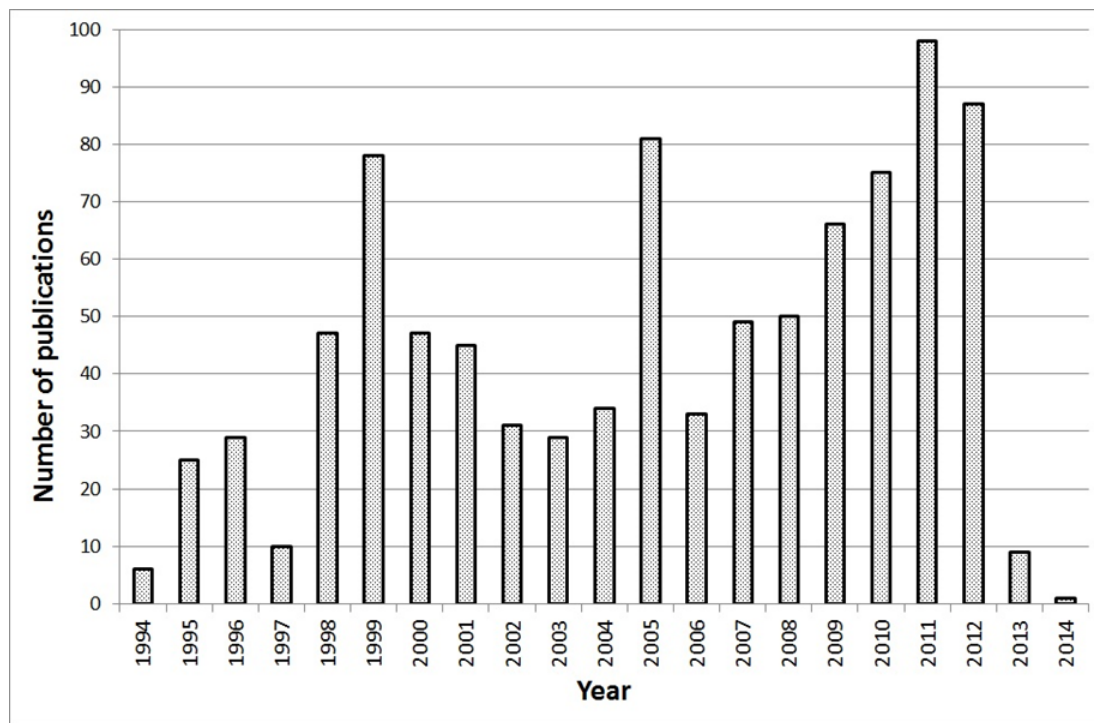

**Figure 1.** Dynamics of annual publications in the field of synthesis, research of properties and application of alkoxides of chemical elements according to data from [4].

## 2. The Basic Properties of Alkoxides

Alkoxides, products of replacement of atoms H in hydroxyl group of the molecule of alcohol on atom of a chemical element. As is known almost of all elements of the Periodic table of D.I. Mendeleev have alcohol derivatives. This class of compounds can be presented in the following generalized formula:

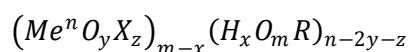

where: *Me*- a chemical element; *R* - hydrocarbon radical of alcohol; *n* – oxidation level of chemical element in the alkoxide; *m* - alcohol basicity; *X* = OH, Hal, etc.

Unlike hydrous oxides of chemical elements, properties alcohol derivatives are determined not only by the nature of the element, but also depend on the nature of alcohol radical, including in the molecule. Therefore, the classification of alcohol derivatives of various elements of the Periodic table, adopted the acidity of alcohol (i.e., the mobility of hydrogen atom in an alcohol hydroxyl) and electro-negativity [4-7]. The most widely simple metal and metalloid alkoxides, created on the basis of simple monobasic alcohols. From this point of view, we can distinguish three groups of compounds, which have the following general formula:

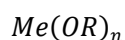

1. Compounds, formed by the elements, with distinct metallic properties and radicals of alcohols which have most strongly acidic ( $pK_{dis} \leq 10$ ), in comparison with other alcohols. This type includes derivatives of alkaline, alkaline-earth metals and thallium (I) with phenols, naphthols, antrols and other organic compounds of aromatic series, whose molecules hydroxyl groups are associated with carbon atoms in the aromatic ring. These compounds have the character of such salts and, as salts of the strong bases and the average strength of acids, they can live in water solution. When dissolved in water, they are insignificant hydrolysis, giving the buffer properties of their solution. They are not soluble in organic solvents (even in absolute low molecular weight alcohols), have, as a rule, specific melting point, high thermal stability and practically does not exist in the gaseous state [5].

2. The other group consists of derivatives of non-metallic and metalloid elements and alcohols having a weak acid function. These compounds represent - esters of inorganic acids. They are characterized by low

melting and boiling points, high vapor pressure, solubility in organic solvents and instability even in relation to water traces. Molecules of such esters have very low polarity; they are usually highly associated and prone to complex formation. Typical representatives of complex ethers can be, for example, alkylborates, whose properties are considered in detail in [8-12]. However, it should be noted that the above General characteristics of the compounds of this group largely inherent in alcohol-derived metals III-VIII group of the Periodic table [5-7, 13-17].

3. Typical representatives of compounds of the third group of alkoxides, are compounds, which include the active metal and alkoxide radical of alcohol, acid dissociation constant of which  $pK_a \gg 10$ . This group includes derivatives of metals I, II main subgroup of the Periodic table, thallium(I) and aliphatic alcohols. The nature of chemical bonds Me—OR they occupy an intermediate position between the polar phenolates and nonpolar esters, which determines the peculiarities of their properties. These alkoxides, as esters of inorganic acids, extremely sensitive to the action of a moisture, and sometimes (as in the case of Li) associated and they often observed complex formation. By analogy with the phenolates, alkoxides this group is capable of electrolytic dissociation. Their alcoholic solutions have significant electro conductivity and sometimes react in ionic form; they are not soluble in organic solvents (except alcohols). However, unlike the compounds of the first two classes, these alkoxides not melt and not distillate, their thermal decomposition occurs at 200-300 °C [4,5]. Comparative properties of alkoxides various elements presented in table 1.

**Table 1.** Physico-chemical properties of alkoxides of different chemical elements [4-21].

Compound	$m^*$	$d_4^{20}$	T melt, °C	Tboil., °C/mm Hg	Solubility in ROH (20°C), % mass
NaOCH <sub>3</sub>	∞	1,28	400 (decompose)	—	32,1
NaOC <sub>2</sub> H <sub>5</sub>	∞	—	320	—	21,8
NaOC <sub>3</sub> H <sub>7-i</sub>	∞	—	—	—	18,9
KOC <sub>3</sub> H <sub>7-i</sub>	∞	—	—	—	18,3
LiOCH <sub>3</sub>	∞	1,30	310	—	12,5
LiOC <sub>2</sub> H <sub>5</sub>	∞	—	325 (decompose)	150/0,01 (sublimate)	16,4
LiOC <sub>4</sub> H <sub>9-tert</sub>	6	1,471	—	110/0,1 (sublimate)	—

\*  $m$  - Degree of association; the arrow shows the change  $m$  during aging.

In recent years began to develop intensively work on the synthesis of mixed alkoxide compounds. This is due, primarily, to the development of such industries as nanotechnology, technology of high-temperature superconductors, electronics, etc. [19-21]. However, in the published works, little attention is paid to the technological aspects of production and use of alkoxides chemical elements. In this connection, in the present work, we attempted to fill this gap, for alkoxides of alkali metals and, in particular, alkoxides of sodium and potassium.

### 3. Production Technology of Alkali Metals Alkoxides

#### 3.1. Direct Synthesis in the Interaction of Metal and Alcohol

Alkali and alkaline earth metals alkoxides produced by interaction of metal with alcohol. Sometimes this reaction occurs in solution of hydrocarbon or liquid  $\text{NH}_3$  [5]. This is the easiest and most reliable way of these metals alkoxides preparation. However, the industrial implementation of this process is associated with a number of technical troubles, due to the high activity of these metals. Already with the same metal as potassium is almost impossible to work under normal conditions, in connection with the self-ignition in the air. The most common are very developed and industrial processes for the manufacture of sodium alkoxides. The process of interaction of metallic sodium with alcohols occurs rapidly; however, this process is well regulated. The main factor determining the rate of interaction of sodium with alcohols is the surface area of contact between the solid and liquid phases. The second important factor is the degrees of acidity have used alcohol. Kinetic curves of the interaction of sodium metal with various alcohols are presented in Figure 2. Figure 3 shows the dependence of the rate constant of the interaction of metallic sodium with various alcohols, depending on their acid dissociation constants  $pK_a$ , for lump sodium sizes  $50 \times 50 \times 50 \text{ mm}$ .

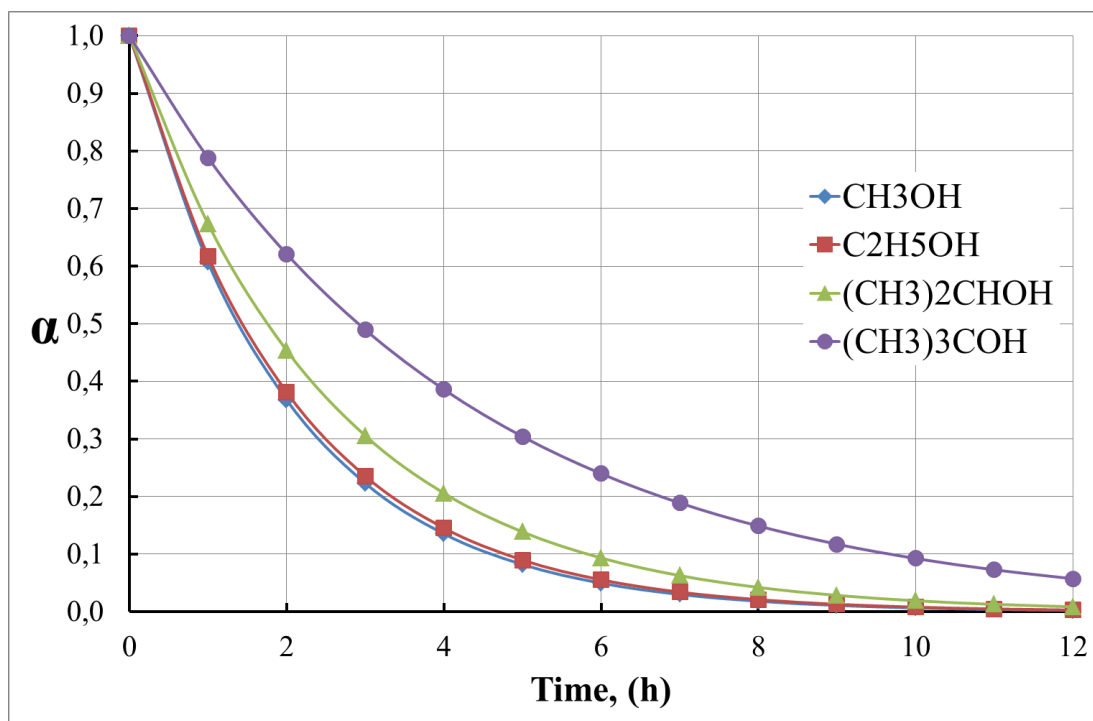

**Figure 2.** Kinetic curves of the interaction of sodium metal with various alcohols. Experiments were conducted using sodium lump size  $50 \times 50 \times 50$  mm.

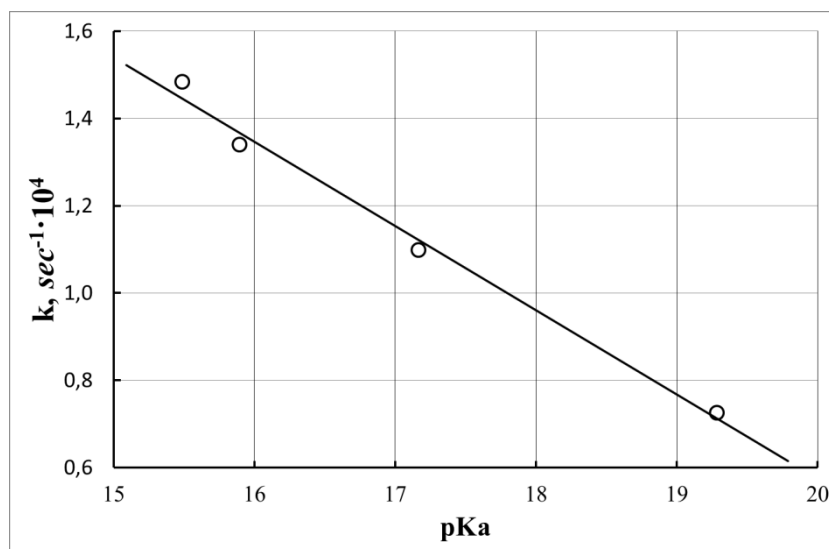

**Figure 3.** The dependence of the rate constant of the interaction of metallic sodium with various alcohols, depending on their acid dissociation constants  $pK_a$ , for lump sodium sizes  $50 \times 50 \times 50$  mm. [4]

### 3.2. Interaction Metals Oxides and Hydroxides with Alcohols

In [3-5] indicated that alkoxides alkaline, alkaline-earth metals, Tl(I), V(V), Mo(VI), Re(VII), Os(VIII) also obtained by alcoholysis of their oxides or hydroxides:

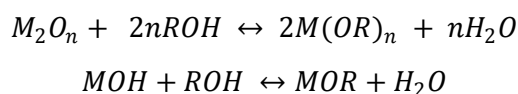

The equilibrium is shifted to the right binding or removes the water by distillation. However, the experiments showed that thus interact only certain metals oxides. These oxides  $Re_2O_7$  and  $OsO_4$  generally oxidize alcohols to the appropriate acids and the formation of alkoxides not observed. With hydrous oxides, the situation is even more complicated. According to the above scheme with real yield we could get only alkoxides of potassium and other heavy alkaline metals. And moreover, alcohols not reacted with vanadium and molybdenum acids. The most comprehensively studied the interaction of sodium hydroxide with various alcohols. Within a few days have produced only a small amount of sodium methylate and ethylate, with a yield less than 0.5%. Ethanol and other heavier alcohols themselves acted as a dehydrating agent, and the resulting distilled water in the form azeotrope. The use of such azeotropic agents of water distillation, as benzene and toluene, practically not changed the situation [4]. Technological scheme of this process is shown in Figure 4.

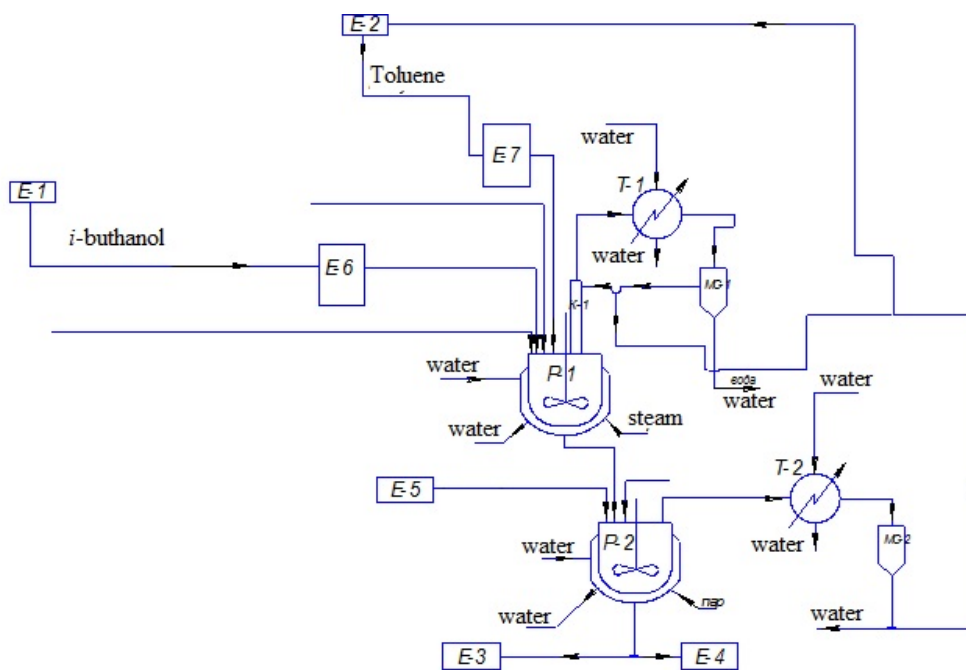

**Figure 4.** Technological scheme for obtaining potassium *i*-butoxide, by azeotropic distillation of water.

This scheme was developed only technology of production of potassium butoxide. The potassium hydroxide solution was loaded into a reactor. Here download the estimated amount of *i*-butanol and benzene. Benzene is used as a component forming azeotrope with water and butanol. Boiling point azeotrope benzene-water-butanol 92÷94 °C.

When you start, fill the measuring tank-separator by *i*-butanol, once on several syntheses. In the reactor start the mixer and send superheated steam in steam-water jacket. Benzene and *i*-butanol circulates in the synthesis process. Formed ternary azeotrope (water-benzene-butanol) out of the top of the reactor and gets in the rectification column, which is enriched azeotropic mixtures. The speed and extent of the process are controlled by means of thermocouples installed on top of the column and allocation of water in the measuring tank-separator. Temperature 92-107 °C on the top of the column corresponds with the beginning and end of the reaction. The azeotropic vapors are condensed in the heat exchanger cooled by water. From a heat exchanger, separated liquid phase of water, butanol and benzene, leaving the tube space, should have temperature of about 25°C. Benzene, butanol and water go in measuring tank-separator, a pre-filled *i*-butanol. In the process of synthesis of the product, benzene and butanol from the measuring tank-separator is returned via the hydraulic lock back into the system of synthesis. The water through the lower fitting of measuring tank-separator, excreted from the cycle.



The process is complete when the measuring tank-separator ceases to stand out of the water and the temperature of the top of the column is 98-99°C. After the end of the synthesis distilled benzene and excess of *i*-butanol, and the finished products pour out.

### 3.3. Exchange reactions with alcohols, transesterification

The most easily derived alkoxides metals with light alcohols, however, the process of synthesis of alkoxides based on fatty and complex alcohols, much more difficult. The decision of problems of synthesis of such alkoxides is achieved by using the exchange reactions with the corresponding alcohols, by analogy with the process of esters transesterification. These processes are as follows:

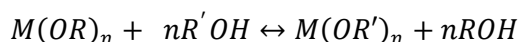

The equilibrium of the reaction of transesterification alkoxide other alcohol shift to the right distillation more easily boiling of alcohol or distillation of azeotrope ROH with benzene or frequent introduction of new portions ROH. In case when both of alcohols have similar boiling point, suitable replacement ROH on an ester:

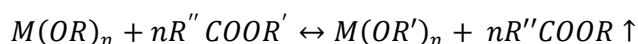

The displacement of equilibrium to the right side is usually by distillation of the more volatile alcohol or ester. This process was performed on a process plant is similar to that described in section 3.2.

### 3.4. Electrochemical Methods in the Processes of Sodium and Potassium Alkoxides Synthesis

To slow down the rate of interaction of sodium and potassium with alcohols, their amalgam has been used. The amalgam was prepared by electrolysis of sodium hydroxide. The interaction process alkali metal amalgam flows quietly enough, even in the case of methyl alcohol and potassium amalgam.

Technological scheme includes three stages: electrolysis of NaOH solution at ordinary electrolyze with flow mercury cathode; dissolving amalgam on the anode in an alcohol solution and recovering sodium or potassium, in the form of alkoxides. The second stage proceeds as follows: sodium or potassium amalgam serves as the anode; the electrolyte is a solution of a metal alkoxide in the corresponding alcohol. The perforated steel plate used as a cathode. The anode and cathode are disposed horizontally. Sodium metal, standing on the surface of the mercury anode, reacted with the alcohol to form the corresponding alkoxide.

The escaping hydrogen output through the holes of the cathode and comes to the stage of condensation of alcohol vapor. The proposed method enables the synthesis of alkoxides of sodium and potassium in soft, controlled conditions. Electrolysis system for producing of sodium and potassium alkoxides is shown in Figure 5.

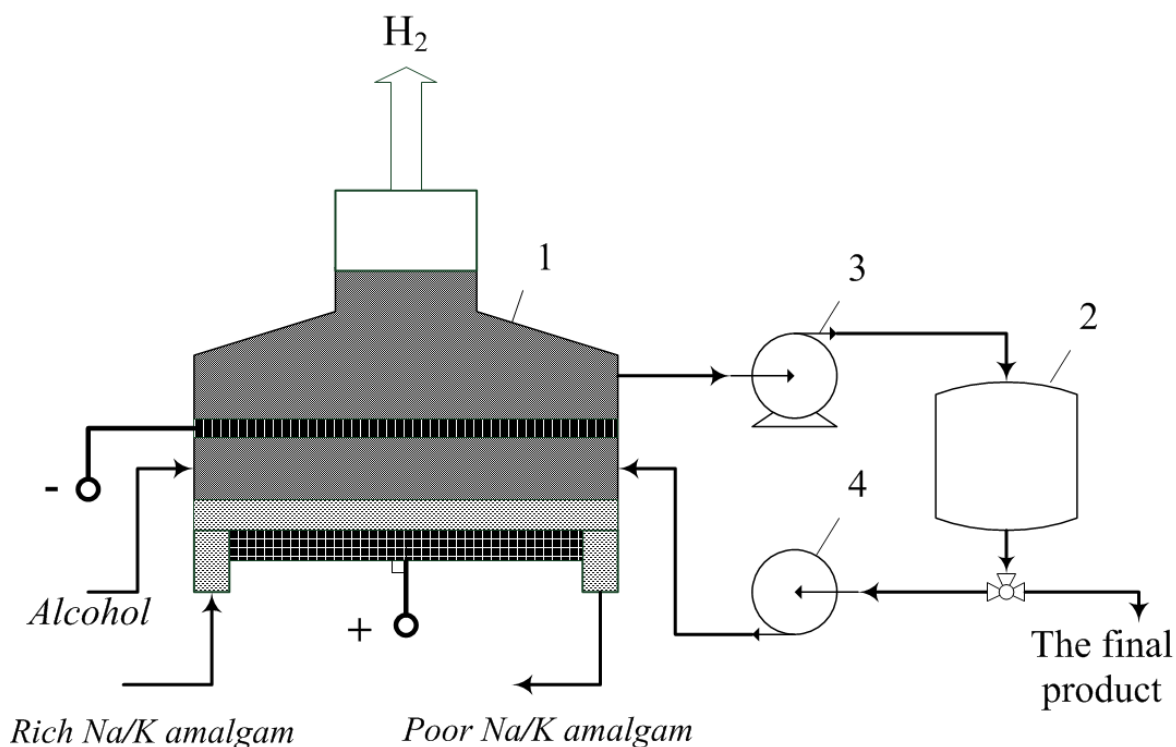

**Figure 5.** Electrolysis system for producing of sodium and potassium alkoxides. 1 – Electrolyze; 2 – Reception capacity for the solution of the alkoxide; 3,4 –Pumps.

The main advantages of the electrochemical amalgam method compared to conventional methods are as follows: low temperature facilitates the production and makes it safer; high output current determines the relatively low power consumption; lower operating costs; no special contact devices with moving parts; no corrosion of equipment.

Obtained after drying and removal of solvent, the sodium and potassium alkoxides have the composition shown in Table 2. Indicators of the technological process are presented in Table 3. The temperature range of the process is in the range from room temperature to a temperature of about 10 degrees less than the boiling point of the corresponding alcohol, which is used for obtaining the alkoxide.

**Table 2.** The composition of sodium and potassium *i*-butyrates

Componen t	Composition, mass%	Componen t	Composition, mass%
NaOC <sub>4</sub> H <sub>9</sub> - <i>i</i>	>99,9	KOC <sub>4</sub> H <sub>9</sub> - <i>i</i>	>99,9
Ca	<0,001	Ca	<0,0005
Cl <sup>-</sup>	<0,004	Cl <sup>-</sup>	<0,001
SO <sub>4</sub> <sup>2-</sup>	<0,005	SO <sub>4</sub> <sup>2-</sup>	<0,002
Pb	<0,001	Pb	<0,0006
Hg	traces	Hg	traces

**Table 3.** Indicators of the technological process

Parameters	Value
Process temperature, °C	20÷140
The voltage on the bath, <i>V</i>	2,5÷3,0
The current efficiency, %	96÷98
Electricity consumption per 1 <i>ton</i> of sodium, <i>kWh</i>	10 000
Consumption of electrodes	Is negligibly small
Corrosion of the equipment	Very low
Environmental conditions	Good

## 4. Conclusions

Thus, the main advantages of amalgam method producing of alkali metal alkoxides, as compared with conventional methods, as follows:

- Slow speed of the process, especially with active alkali metals, making it very safe;
- Low temperature facilitates the manufacture and also makes it safer;
- A high current efficiency determines a relatively low power consumption;
- Lower operating costs;
- There are no problems related with corrosion of equipment;
- Great opportunities of the technological process adjustment.

## Acknowledgements

The authors wish to thank Polymate Ltd. - International Nanotechnology Research Centre and HIT Holon Institute of Technology for their contribution.

## References

- [1]. Bradley D.C., *Progr. Inorg. Chem.*, 2, (1960), 303.
- [2]. Mehrotra R.C., Singh A., *Organometallic Chemistry*, NAI, 2004, 617 p.
- [3]. Bradley D.C, Fisher K.J., M. T.P. *International Rev. Sci. General Chem. of Transition Metals*, ed. D.W.A. Sharp, 5, part 1, Butterworths, London, (1972), 65.
- [4]. Kudryavtsev P. *Journal "Scientific Israel - Technological Advantages"*, Vol.16, no.2, 2014, p. 147-170
- [5]. Turova N.Y, Novoselova A.V., *The alcohol derivatives of alkali, alkaline earth metals, magnesium and thallium (I)* *Russian Chemical Reviews*, 34, (1965), 385.
- [6]. Pinkos R., *Aluminum alkoxides*, *Russ. Chem. Rev.*, 37, (1968), 648.
- [7]. Bradley D.C. *Metal Alkoxides and Dialkylamides*, *Advances in Inorg. Chem. and Radiochem.*, 15, (1972), 259.
- [8]. Toussaint R., *Rev. chim. industr.*, 39, (1930), 162.
- [9]. Toussaint R., *Rev. chim. industr.*, 39, (1930), 226.
- [10]. Toussaint R., *Rev. chim. industr.*, 39, (1930), 290.
- [11]. Toussaint R., *Rev. chim. industr.*, 39, (1930), 322.
- [12]. Bradley D.C., Mehrotra R.C., Rothwell I., Singh A. *Aryloxo Derivatives of Metals*, Academic Press, 2001.
- [13]. Ivanov, S.V. *Getting very pure initial substances for nanotechnology*, Moscow, RF, (2005).
- [14]. Andrianov K.A., *Methods of Organoelement chemistry. Silicon*, Nauka, Moscow, (1968)
- [15]. Tretyakov Yu.D., *"Self-organization processes in the chemistry of materials "*, *Russ. Chem. Rev.*, 72, (2003), 651
- [16]. Suzdalev I.P., Suzdalev P.I., *Russ. Chem. Rev.*, 75, (2006), 715
- [17]. Levitsky M, Zavin B.G., Bilyachenko A.N., *Russ. Chem. Rev.*, 76, (2007), 907
- [18]. Strelnikova, I.E. *Pure metal alcoholates for obtaining of oxide systems*, Moscow, (2005).
- [19]. Roco M.K., Williams R.S. and Alivisatos P. *Nanotechnology in the next decade. Forecast research directions*. M., "Mir", (2002).
- [20]. Beliakov A.V., *The Methods of obtaining of inorganic non-metallic nanoparticles*. M, Ed. the centre of MUCTR them. D.I. Mendeleev, (2003).
- [21]. Pool Ch., Owens V, *Nanotechnology*, M, Technosphere, (2004).